

VHF MARINE DSC RADIO

HM390-BB

HM390C-BB

HM390S-BB

HM390-BBN

User Manual

HIMUNICATION



<http://www.himunication.com>

Please Scan the QR Code to Download
EN/FR/ES/IT/NL Multi-language User Manual

Contents

EU Regulatory Conformance.....	02	UIC/AIS Control.....	18
Installation.....	03	TRIW/HAIL (Tri Watch/Hailer).....	18
Handset/Back Panel/Wiring diagram.....	03	GPS/MOB Key.....	18
Product Model Difference Table.....	05	DW/ FOG (Dual Watch/Foghorn).....	18
Back Panel.....	06	MEM Key.....	19
Connection cables The table.....	07	Scan Key.....	19
Accessories included.....	07	Hi/Lo/Lock.....	19
Optional accessory.....	08	Up/Down Key.....	19
LCD Display.....	09	LOC/DX.....	19
Main Menu Operation on Screen DSC Menu.....	09	16/9 Key.....	19
Detailed entrance for each catalogue.....	09	Select second priority channel.....	19
MY MMSI ID setup.....	10	CALL/MENU.....	20
Individual Call/Position Request.....	10	Back Light.....	20
All Ship Call.....	11	CH*/WX.....	20
Receive Call Log.....	11	Other Features and Solutions.....	20
Send Call Log.....	12	Special function keys.....	20
Phone Book.....	12	TX Time Out.....	20
DSC Setup.....	12	The Local Time & Date on Screen.....	20
Main Menu.....	12	NMEA 0183 and NMEA 2000.....	21
VHF Operation.....	13	Compass safe distance is 0.8m.....	21
GPS Setup.....	14	Appendix A – List of Abbreviations.....	21
AIS Setup (Only HM390S).....	15	NMEA2000 COMMUNICATION PGN.....	22
ATIS Operation.....	15	International Marine VHF Channels & Frequencies.....	23
DSC Operation.....	16	U.S. Marine VHF Channels and Frequencies.....	25
System Config.....	16	Canadian Marine VHF Channels and Frequencies.....	27
Distress Menu & Send the Distress Message.....	16	European Private Channels and Frequencies.....	30
AIS Operation(Only HM390S).....	17	Weather Channels and Frequencies.....	30
Key Operation.....	17	Specifications.....	31
Power on/off & rotate to get up/down function.....	17	Declaration of Conformity.....	32

EU Regulatory Conformance

As certified by the qualified laboratory, the product is in compliance with the essential requirements and other relevant provisions of the Directive 2014/53/EU. Please note that the above information is applicable to EU countries only.

Manufacturer: HIMUNICATION

Trademark number: 11005103

Address: 7th Floor, building 13, Run Dong Sheng Industrial Park, National Road 107, Longzhu community, Xixiang, Baoan district, Shenzhen, China

Warning - Limitations on Use

This HM390S-BB product contains a simple PPI chart, only as an aid to navigation for reference. Only Official Government Charts and Notice to Mariners contain all the current information needed for safe navigation. This product's feature cannot be relied on as complete or accurate and may vary depending on location. It's the captain's responsibility to use official government charts, notices to mariners, caution, sound judgment and proper navigational skills when operating their boat using this product.

1 .Installation

Place and fasten radio on the deck by 4 screws;

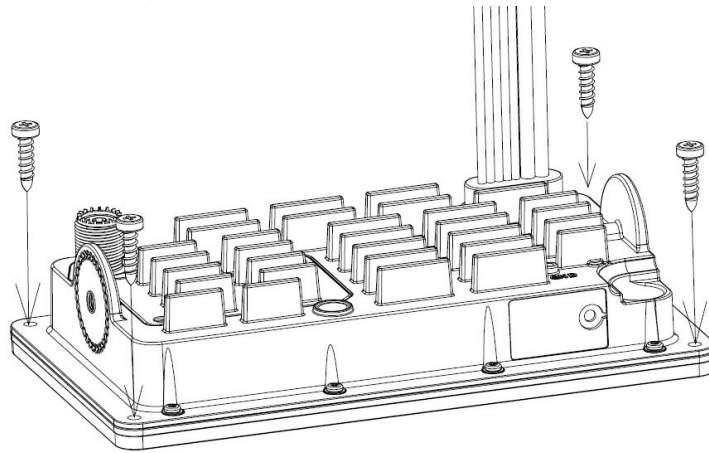

2. Handset/Back Panel/Wiring diagram

Handset

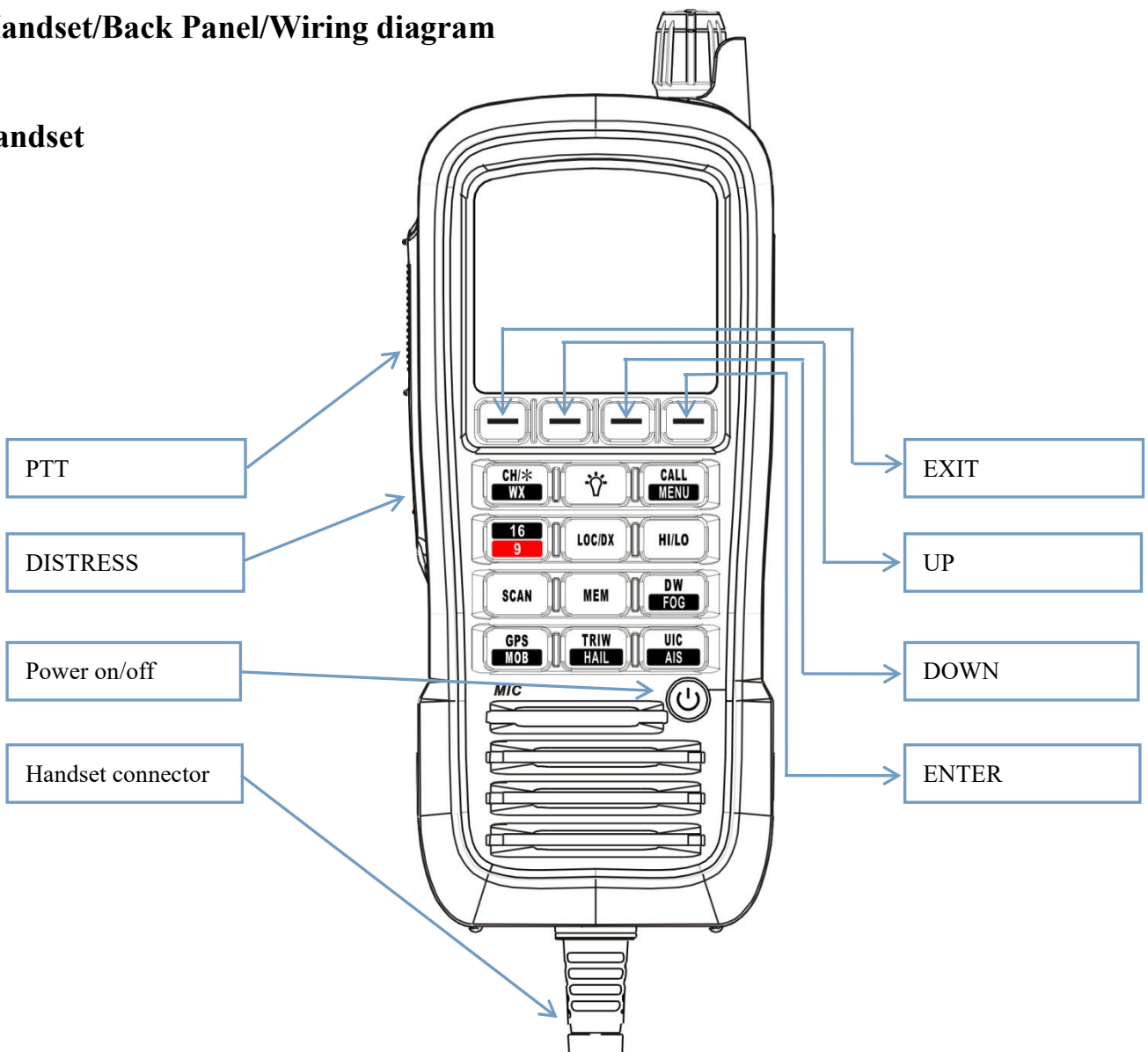

- (1) CH*/WX—short press to enter private channel, long press to enter weather channel (only available in US)
- (2) Back Light On/Off—short press to back light On/Off.
- (3) Call/MENU—short press to enter “ Menu”, long press to enter “Main Menu”.
- (4) 16/9—short press to enter channel 16 or press this button to quit all other modes and back to the priority channel quickly, long press will get second-priority channel 09 or any channel that you’ve set as second-priority channel.
- (5) LOC/DX—short press to get conversion between local and distance mode (DX allows normal receive sensitivity; and “LOCAL” eliminates receiver noise, but degrades receiver sensitivity meanwhile “LOCAL” icon display on LCD).
- (6) HI/LO/LOCK—short press to toggle between 25watt and 1 watt output. “HI” or “LO” icon appears on LCD display to indicate setting.
- (7) SCAN—short press to enter all scan/all memory scan, long press to enter priority all/memory scan.
- (8) MEM—short press to enter memory mode, long press to save/delete memory channel.
- (9) DW/FOG—short press to enter Dual Watch Mode, long press to enter “Foghorn Menu”.
- (10) GPS/MOB—short press to get GPS setting, long press to get MOB activated.
- (11) TRIW/HAIL—short press to enter Tri Watch Mode, long press to enter “HAILER LISTEN MODE” and set volume as you wish.
- (12) VOL/AIS—short press to enter volume set, long press to enter AIS (Automatically Identification System HM380S-BB only).
- (13) Handset connector
- (14) Soft key 1 EXIT
- (15) Soft key 2 UP
- (16) Soft key 3 DOWN
- (17) Soft key 4 ENTER
- (18) DISTRESS—Pull up key cover and press hold on to start Distress Alert Calling if you programmed your radio with an MMSI number.
- (19) Power on/off—short press to turn it on, long press to turn it off.
- (20) PTT key----push this key to sent out radio frequency signals.

Product Model Difference Table

Multiple Models name	Differences Items Details
HM390S-BB	HM390S-BB has the completed accessories:main unit+AIS receiver+NMEA2000+handset w/LCD +(Optional to support the second handset w/LCD+GPS antenna)
HM390C-BB	HM390C-BB has the completed accessories:main unit+NMEA2000+handset w/LCD +(Optional to support the second handset w/LCD+GPS antenna)
HM390-BB	HM390-BB has the completed accessories:main unit+handset w/LCD +(Optional to support the second handset w/LCD+GPS antenna)
HM390-BBN	HM390-BBN has the completed accessories:main unit w/o DSC+handset w/LCD +(Optional to support the second handset w/LCD+GPS antenna)

Back Panel

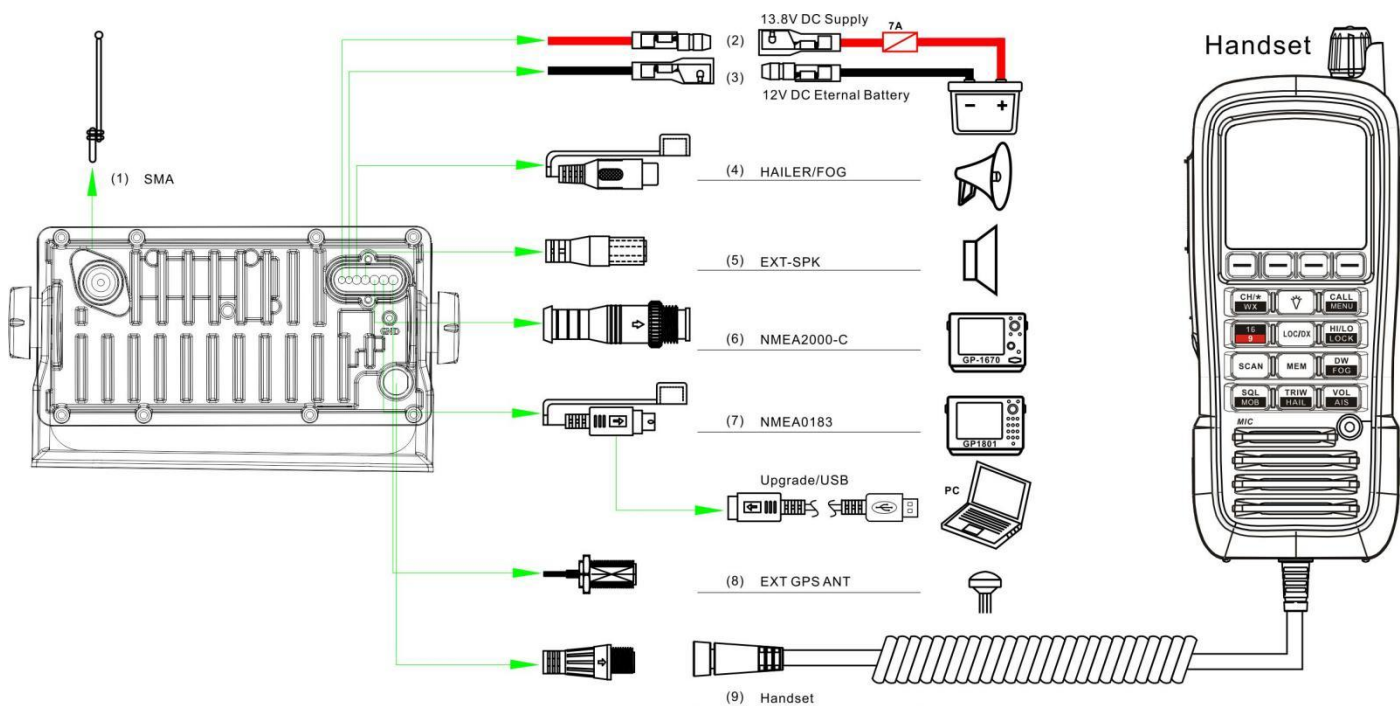

- 1、RF antenna port SO239 (Female)
- 2、Power + wire (red, 210 mm length)
- 3、Power – wire (black, 210 mm length)
- 4、Hailer/Fog cable with 3.5 mm plug (180 mm length)
- 5、External speaker cable with 3.5 mm plug (180 mm length)
- 6、NMEA2000 cable with Micro-C connector (Male)
- 7、NMEA0183/update USB cable with PS2 connector (Male)
- 8、Extension GPS antenna cable with SMA connector (Female)
- 9、Optional handset port

As above show, the “number in picture” correspond to “wiring number” also correspond to “the number in the below table”
The details please check the below table.

Connection cables The details please check the below table

Serial Number	General Description	Function Description	Different Color Code of the cable wires	
(1)	RF antenna connector SO239 (Female)	VHF antenna	-	-
(2)	Red & Black Power	Power supply wires	Red	Power+ +13.8V
(3)			Black	Power- GND
(4)	Audio Connector RCA (Phone) Plug	Hailer/Fog	White	SPK+
			Black	SPK-
(5)	Audio Connector Black 3.5 mm Plug	External Speaker	Red	AUDIO-OUT
			Black	GND
			-	NC
(6)	NMEA2000 cable with Micro-C connector (Male)	NMEA2000 network	Black	CANH
			Red	CANL
(7)	NMEA0183/update USB cable with PS2 connector (Male)	NMEA0183 network Software upgrade	Green	USB-TX
			Brown	0183_OUT
			White	NC
			Orange	0183_IN
			Red	USB-RX
			BARE WIRE	GND
(8)	Extension GPS antenna cable with SMA connector (Female)	EXT GPS ANT	-	-
(9)	Optional handset port	Remote command microphone (Optional)	-	-

Accessories included

1.5m power cable - 7 A fuse

Cable NMEA0183 0.4 m

External Output Cable / Voice Holder

A Plug & Play GPS antenna can be connected directly to the VHF.

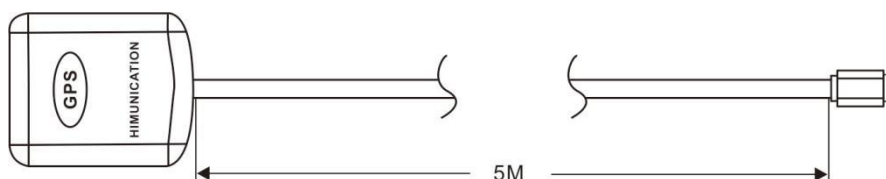

Optional accessory

1、 Optional accessory Cable-Dashboard cable (Dashboard TO Handset Terminal) 6 meters Male/Female connectors of 7 pin round socket - 6meters or 12meters

Note: Standard Set Cables - Black Box Main Unit TO Dashboard cable, Male/Female connectors of 7 pin round socket - 3meters

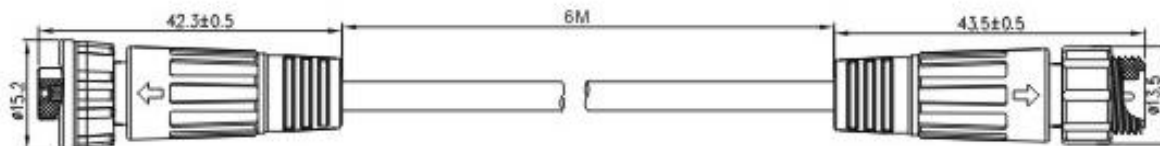

2、 Optional accessory Handset

Optional accessory HS20+ wired handset and HS20W wireless handset

Handset with rotary switch



3.LCD Display



DSC Menu
Individual Call
Position Request
All Ship Call
Group Call
Test Call
Receive Call Log
Send Call Log
Phone Book
DSC Setup
My MMSI ID
EXIT ▲ ▼ ENTER

4. Main Menu Operation on Screen

DSC Menu

Short press the CALL/MENU key will be displayed as below on LCD:

Detailed entrance for each catalogue as shown below:

Individual Call▶	Individual Call	Receive Call Log▶	Receive Call Log
	Input Address		Distress Call
	From Phone book		Others Call
Position Request▶	Position Request	Send Call Log▶	Send Call Log
	Input Address		Distress Call
	From Phone book		MOB Call
All Ship Call▶	All Ship Call	Phone Book▶	Others Call
	Safety		Phone Book
	Urgency		Buddy List
Group Call▶	Group Call	DSC Setup▶	Group List
	Input Address		DSC Setup
	From Phone book		Position Input
Test Call▶	Test Call	My MMSI ID▶	Position Reply
	Input Address		Test Ack
	From Phone book		My MMSI ID
			10000008

MY MMSI ID setup

Firstly, long press CALL/MENU key to enter “Main Menu”.
Secondly, select “DSC Operation” to enter “MY MMSI ID”.
Then you can set up your related MMSI ID as below, generally you need to double confirm the MMSI ID. Once confirmed, your MMSI ID will be locked by this radio.

```
My MMSI ID
123456789

EXIT
```

When input 9 digits, UP/DOWN key used for choosing the number from 1 to 9. You need to input all numbers from the left to right one by one until all finished. Once fulfilled 9 digits, then press “ENTER” to confirm.

```
My MMSI ID
Input MMSI
123-----

EXIT ▲ ▼ ENTER
```

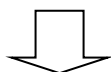

```
My MMSI ID

123456789

EXIT
```

Note. You must enter your user MMSI before you can access the DSC functions. This is a once-only operation.

Individual Call/Position Request/Group

Call/Test call

Press the “CALL/MENU” key and choose “Individual Call”, then choose “Input Address” or “From Phonebook”.
Take individual call as example-

First select the “Input Address”, then input 9 MMSI digits manually such as 123456789 for your address as below:

```
Input Address
Input 9 digits
0-----

EXIT ▲ ▼ ENTER
```

Then select the type of individual call such as Routine

```
Individual Call
Routine

EXIT ▲ ▼ ENTER
```

Next select the preferred channel such as 01 port operation and confirm to call

```
Individual Call
Select Channel:
01 port ops/vts
03 unauthorized
05 port ops/vts
06 inter ship
07 commercial
08 commercial

EXIT ▲ ▼ ENTER
```

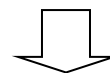

```
Individual Call
To: 100000000
Safety
Telephony by
Channel 16

EXIT CALL
```

Then the individual call is sent as below shown

```
DSC 📶 USA
1W

16

SQL:5
VOL:4 SAFETY
Elapsed 00: 56

EXIT
```

All Ship Call

Select the All Ship item

```

DSC  Menu
Individual Call
Position Request
All Ship Call
Group Call
Test Call
Receive Call Log
Send Call log
Phone Book
DSC Setup
My MMSI ID

EXIT ▲ ▼ ENTER
    
```

The All Ship Call is sent

```

All Ship Call
Safety
Urgency

EXIT ▲ ▼ ENTER
    
```

```

Safety
Select Channel:
01 telephone
02 telephone
03 telephone
04 port ops
05 port ops/vts
06 safety
07 port ops
08 commercial

EXIT ▲ ▼ ENTER
    
```

```

All Ship Call
To : All Ship
Safety
Telephone by
Channel 16

EXIT CALL
    
```

```

DSC USA
1W
16
SQL:2
VOL:4 DISTRESS
Elapsed 00: 04
EXIT
    
```

Receive Call Log

When received DSC, you can check those messages from the "Distress Menu" and see the exact message

```

DSC  Menu
Individual Call
Position Request
All Ship Call
Group Call
Test Call
Receive Call Log
Send Call Log
Phone Book
DSC Setup
My MMSI ID

EXIT ▲ ▼ ENTER
    
```

```

Receive call log
Distress call
Others call

EXIT ▲ ▼ ENTER
    
```

```

Received DSC
Distress cancel
Undesignated
From: 123456789
GPS POS: Unknown
Time: Unknown

EXIT DELETE
    
```

Send Call Log

Press “CALL/MENU” key to choose “Send Call Log” item and see previous distress call, MOB call and other call that you have sent.

DSC Menu

Individual Call
Position Request
All Ship Call
Group Call
Test Call
Receive Call Log
Send Call Log
Phone Book
DSC Setup
My MMSI ID

EXIT ▲ ▼ ENTER

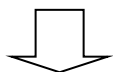

Send Call Log

☎ Distress Call
☎ MOB Call
☎ Others Call

EXIT ▲ ▼ ENTER

Phone Book

Press “CALL/MENU” key to choose “Phone Book” item and can check the contacted ship by “Buddy List” and “Group List”

DSC Menu

Individual Call
Position Request
All Ship Call
Group Call
Test Call
Receive Call Log
Send Call Log
Phone Book
DSC Setup
My MMSI ID

EXIT ▲ ▼ ENTER



Phone Book

Buddy List
Group List

EXIT ▲ ▼ ENTER

DSC Setup

DSC Menu

Individual Call
Position Request
All Ship Call
Group Call
Test Call
Receive Call Log
Send Call Log
Phone Book
DSC Setup
My MMSI ID

EXIT ▲ ▼ ENTER

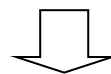

DSC Setup

Position Input
Position Reply
Test Ack

EXIT ▲ ▼ ENTER

Main Menu

Long press the CALL/MENU key will display as below:

Main Menu

VHF Operation
GPS Setup
AIS Setup
ATIS Operation
DSC Operation
System config

EXIT ▲ ▼ ENTER

Detailed entrance for each catalogue as shown below:

VHF Operation	Channel Band Set	ATIS Operation	My ATIS ID
	Priority 2nd Ch		ATIS Function
GPS Setup	GPS Source	DSC Operation	My MMSI ID
	GPS Setting		DSC Function
	NMEA0183 Setting	System Config	Back Light lumi
	GPS ALARM		Key Beep
AIS Setup	AIS Output		Version Info
	AIS Display Set		Factory Reset
	AIS ALARM	Language Select	

VHF Operation

Long press the CALL/MENU key to enter “VHF Operation’

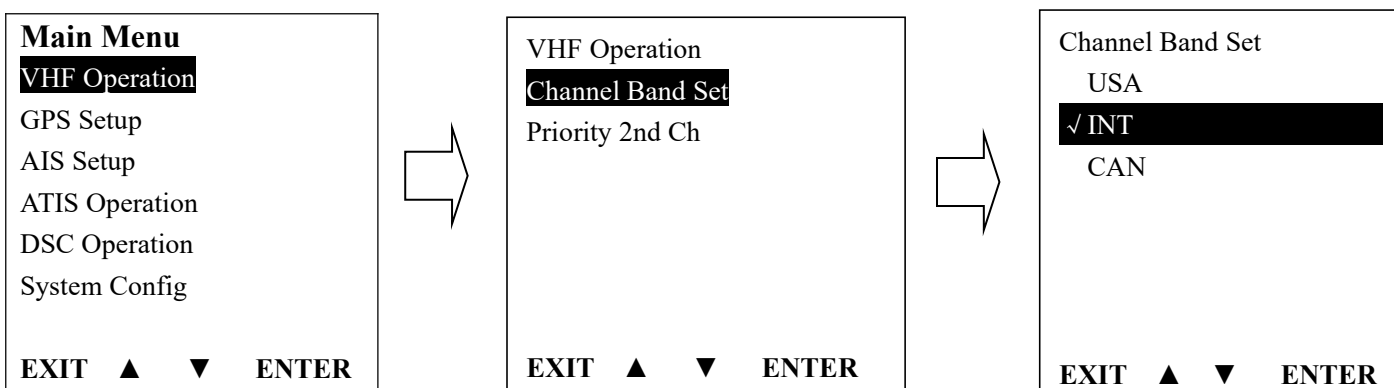

For priority 2nd Ch, you can select your preferred channel from below as your priority second channel.

Priority 2nd Ch	
Select Channel:	
01	telephone
04	port ops
05	Portops/vts
06	safety
07	Port ops
EXIT ▲ ▼ ENTER	

GPS Setup

Click the “GPS Setup” to enter “GPS Setup” item for setup as below shown.

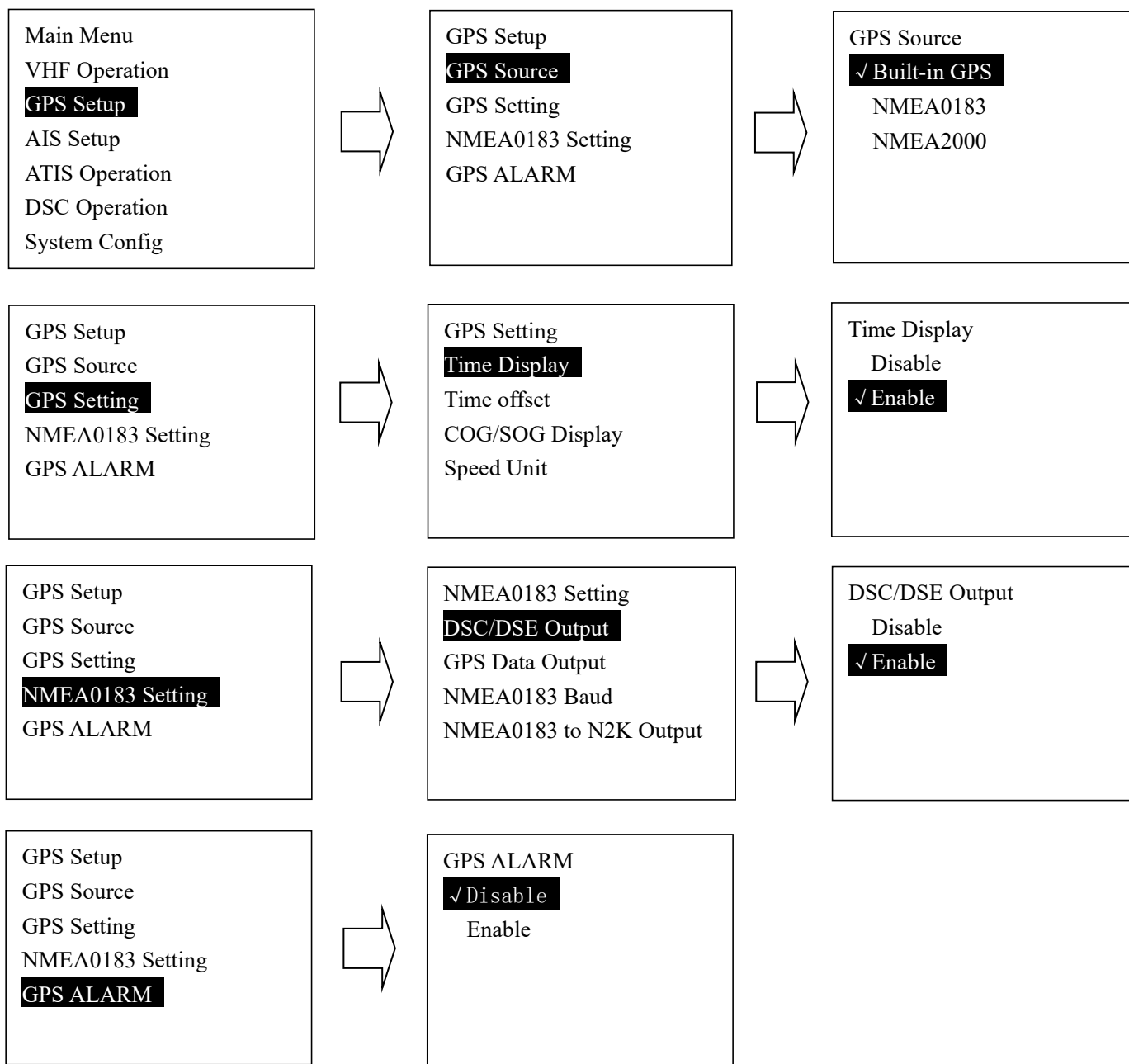

Follow like this, you can setup your priority as you wish.

AIS Setup (Only HM390S-BB)

Long press the CALL/MENU key to enter “AIS Setup” item for setup as below shown

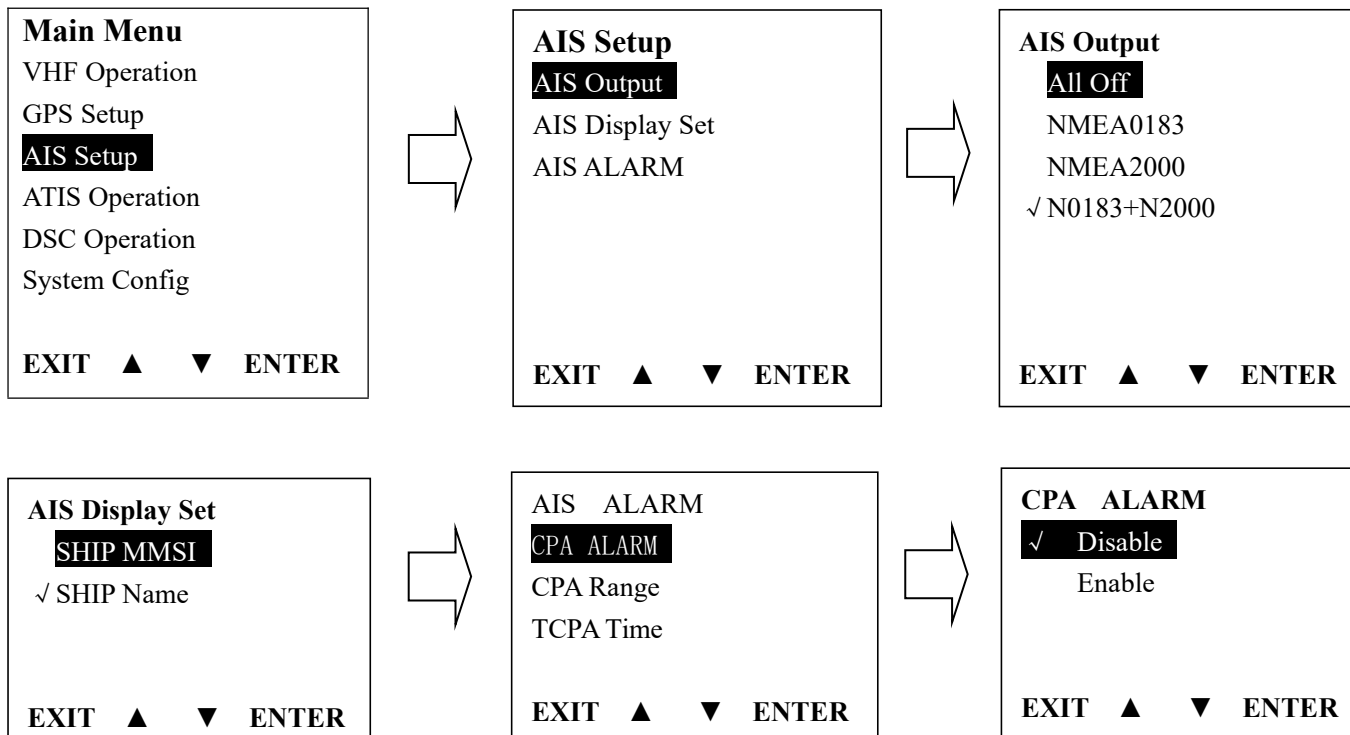

CPA Alarm enable Choose “Disable” or “Enable” item to enter disable or enable AIS alarm, then press “ENTER” key to confirm.

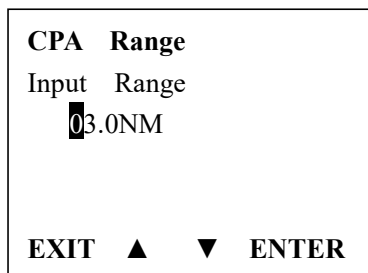

CPA Range (Closest point of approach) Alarm distance setup
Press UP/DOWN key to input digital one by one, after you have done this, press “ENTER” key to confirm, the maximum input range is 25.0NM, if the input value over than 25.0NM, than this operation is invalid, the system will ask for re-enter, the default CPA value is 1.5NM.

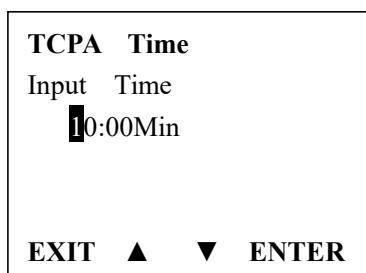

TCPA (Time closest point of approach)Alarm distance setup Press UP/DOWN key to input digital one by one, after you have done this, press “ENTER” key to confirm, the maximum input range is 30 minutes, if the input value is over than 30 minutes, the input is invalid, then the system will ask for re-enter, the default CPA value is 10:00 Min.

ATIS Operation

Long press the CALL/MENU key to enter “ATIS

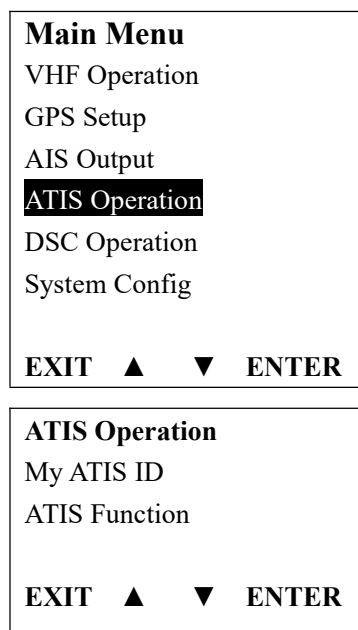

Choose to press for setup or more function as you wish.
 Note. You must enter your user ATIS ID before you can access the ATIS functions. This is a once-only operation.

DSC Operation

Long press the CALL/MENU key to enter “DSC Operation” for setup.

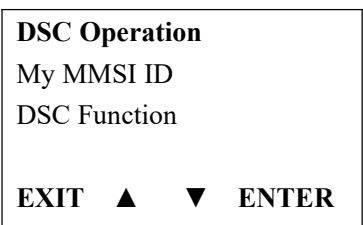
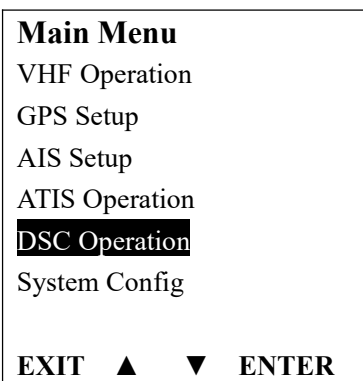

System Config

Long press the CALL/MENU key to enter “system config” for setup.

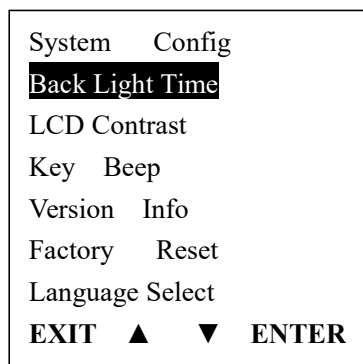
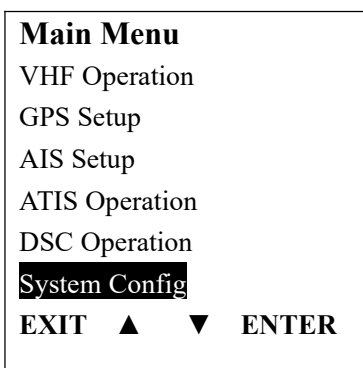

Choose to press for setup or more function as you wish.

Distress Menu & Send the Distress

Message

Pull the DISTRESS red cover and press the DISTRESS key. Then below “Distress Menu” will be displayed on LCD.

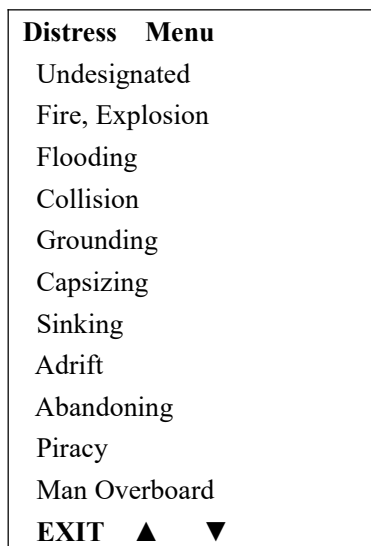

Choose one distress item such as “sinking”, press and hold this for more than 3 seconds for transmitting sinking message out.

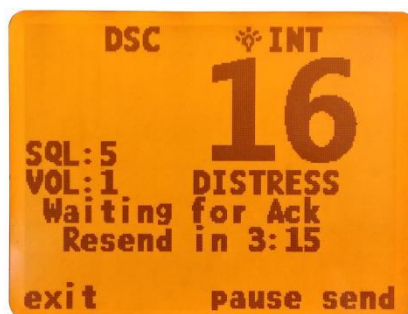
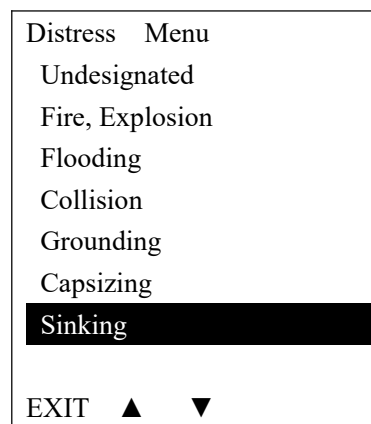

You can also choose to resend, pause or exit after this message was sent.

AIS Operation(Only HM390S-BB)

Long press the 'UIC/AIS' key to enter this interface.

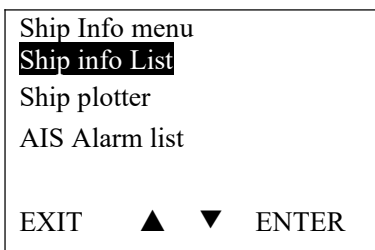

From the AIS ship info menu, you have three options: List mode, plotter mode, AIS Alarm list alarm list mode. If you choose option 'AIS ship info list' and press 'enter', you will open the list mode.

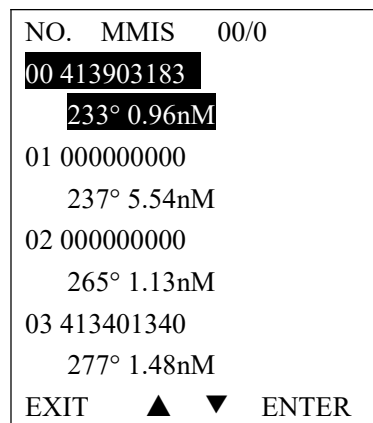

From either mode, you can choose a target with Confirm key, then press enter to display the target details.

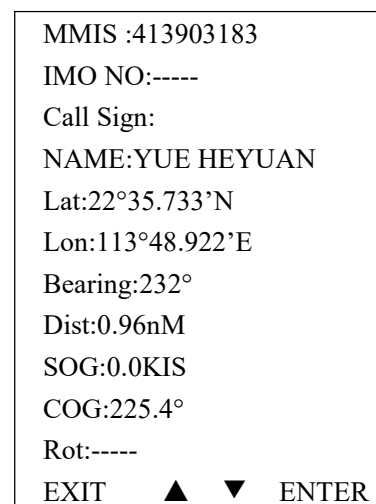
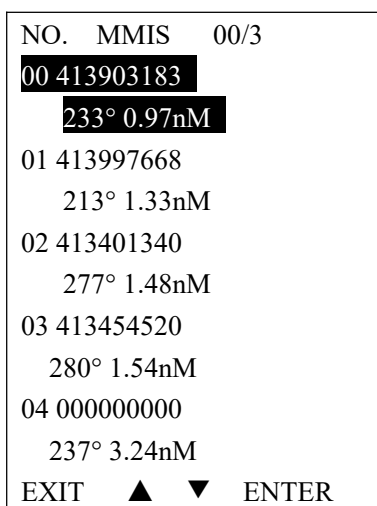

If you choose option 'All ship plotter' and press 'enter', you will open the plotter mode.

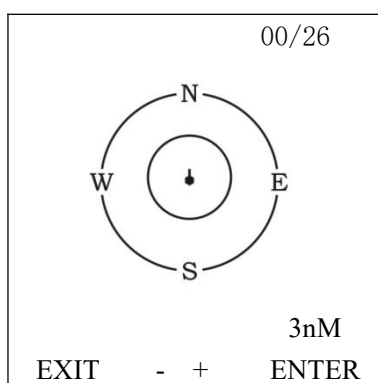

If you choose option 'AIS Alarm List' and press enter, you will open the AIS alarm list mode.

5. Key Operation

Power on/off & rotate to get up/down

function

Short press to turn it on, long press to turn it off. Rotate knob to get up/down function when radio stay powered on.

Special Function of DISTRESS key &

Real-time DSC

When sending distress message:

Pull the Distress key cover and press the Red key into "Distress Menu" selection. Select current distress situation such as "Flooding", then press and hold for 3 seconds, the selected DSC message will be sent.

And this message will be resent within 4 minutes--

Press the “PAUSE” key to pause or resume the resend.
 Press “SEND” to resend immediately.
 Press the soft key below “Exit” icon to exit the current menu and shortly cancelation option of selected DSC alerting will be given for confirmation.

When receiving distress message:

The HM390-BB has two receivers, one receiver used for receiving/transmit voice and another receiver used to continually monitor 70 channel. The DSC function of HM390-BB is operated in separate way which means any arriving DSC message will not be ignored even if you are using HM390-BB for transmitting or receiving. If you want to check those messages, please press “CALL/MENU” to enter “Receive Call Log” for checking all received DSC messages.

UIC/AIS Control

Short press “UIC/AIS” key and “UIC” icon will be shown on LCD.

Long press “UIC/AIS” key and enter AIS (Automatic Identification System) mode (HM390S-BB only). The radio has built-in AIS receiver to meet the demands for vessels to know the position, details and navigational intentions of other vessels within VHF range for improved safety and collision avoidance.

TRIW/HAIL (Tri Watch/Hailer)

Short press “TRIW/HAIL” key can activate the TRI WATCH mode. Monitor CH16, current channel and one programmed channels in cycle.

Long press “TRIW/HAIL” and enter “HAILER LISTEN MODE” for setup as you wish. Sounds received through the horn can be heard through the radio speaker. Press and hold the PTT key and speak your announcement. Release the PTT key to listen.

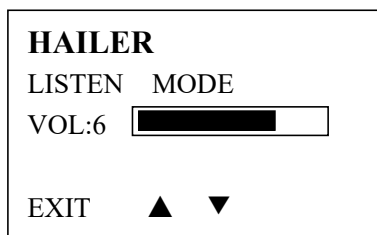

GPS/MOB Key

Short press “GPS/MOB” key to get GPS activated
 long press “GPS/MOB” key “MOB” icon will be shown on LCD, then Press Distress for 3 seconds, Distress call with nature MOB is sent.

MOB mark is outputted via NMEA0183/2000. A MOB mark is immediately sent to the chart plotter to have a position as accurate as possible.

DW/ FOG (Dual Watch/Foghorn)

At the normal mode, short press “DW/FOG” key to activate the DUAL WATCH mode. Monitor the current channel and CH16 in cycle. Whenever weather alert is activated, the WX Alert channel will be monitored once every 4 seconds.

Long press “DW/FOG” key and enter “Foghorn Menu”, then select preferred item from list. Press PTT key on the microphone or handset to sound the horn. The horn will stop when you release the PTT key in Manual Mode .

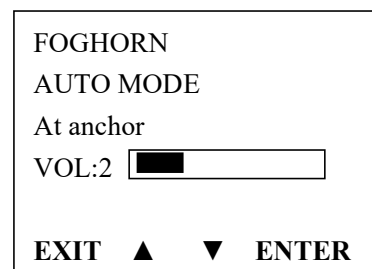
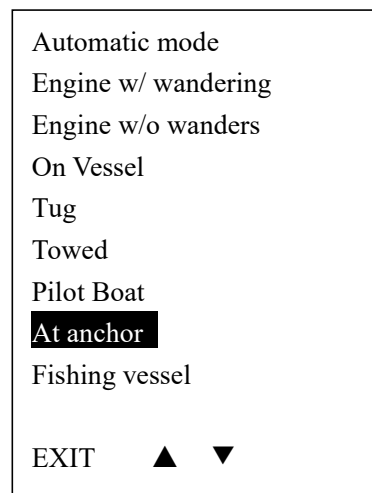
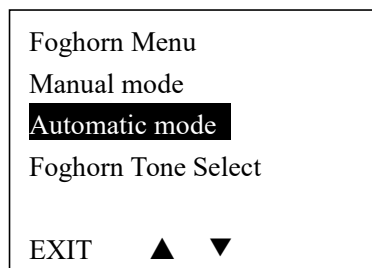

MEM Key

Enter /Exit the memory mode:

Short press MEM key to enter the memory mode, the memory channel will be marked and “M” icon show on the right side next to channel number. At the left side of the current channel will mark a “MEM” icon which means already entered the user memory mode.

At the Memory mode, short press the MEM key to exit the memory mode. The “M” icon and “MEM” icon will disappear.

Adding/Deleting memory CH:

1. At the normal mode, use the “UP/DOWN” key to select desired channel for programming.
2. Long press the MEM key to store up the channel as memory channel.
3. “M” icon will be shown on LCD to indicate the current CH has been saved in the memory.
4. No limitation for saving memory channels.
5. For USA, International, and Canadian Frequency can be saved separately.
6. At the normal mode, use the “UP/DOWN” key to select the memory channel to be deleted.
7. Long press the “MEM” key to delete the selected channel from the memory mode.

Scan Key

Short press “Scan” key is to activate the scan function which is searching for currently all working channels.

All scanning: CH1-CH2-CH3-.....-CH88

Memory scanning: M1 - M2 - M3 - ... M10 - M1- ...

When a signal is detected, the scan pauses until the signal disappears. Long press the Scan Key, to activate the Priority Scan.

Priority memory scanning: M1 - CH 16 - M2 - CH 16 - ... CH 16 - M1 ...

Priority all scanning:

CH1-CH16-CH2-CH16-CH3-CH16-.....CH88-CH16-L1-C H16-

Hi/Lo/Lock

Short press the Hi/Lo/LOCK key will toggle the TX power from Hi to Lo or vice versa. The corresponding “25W/1W” icon will be displayed on the LCD.

Some of the channels (such as channel 16 initially set for high power channel 13&67 initially set for low power) have been initially set to be low power or high power, but can be reprogrammed manually to high power or low power.

Thus, the software needs to check against the channel setting stored in the EEPROM long press the Hi/Lo/LOCK switch lock function

Up/Down Key

At the normal mode, they act as Channel Up/Down key. When it presses > 0.5 sec, the channels will change in a quick way. It returns to normal mode when key press is released.

LOC/DX

Short press to get conversion between local and distance mode (DX allows normal receive sensitivity; and “LOCAL” eliminates receiver noise, but degrades receiver sensitivity meanwhile “LOCAL” icon display on LCD).

16/9 Key

At the normal mode, pressing the 16 / 9 Key (short press to jump to priority CH16 at High Power and long press to jump to priority CH9 at High Power) if the current channel is not the priority channel.

After the channel is tuned to the priority channel, “P-CH” or “P-2nd” icon is lit to indicate the priority CH16 or CH9 has been reached. UP/Down key functions normally.

Select second priority channel

Solution 1: Select the second priority channel by “16/9” key: the second priority channel is set as channel 9 by default. At the normal mode, long press “16/9” key, “P-2nd” will be displayed as the second priority channel on LCD, then long press “16/9” key again, “set P-2nd CH” will be displayed on LCD and the displayed channel will keep on flashing, then press “UP/Down” key to choose your preferred channel as new second priority channel. Finally, long press “16/9” key again to save and confirm it.

Solution 2: Select the second priority channel by “CALL/Menu” key: long press “CALL/Menu” key to select “VHF operation” option, and press to select the “Priority 2nd Ch”, then press and select your preferred channel by “Up/Down” key and confirm it.

CALL/MENU

Short press to enter “DSC Menu”, long press to enter “Main Menu” (detailed operation please see 3. Main Menu Operation on Screen)

Back Light

Short press to switch the Back Light On and Off. Short Press ‘Backlight’ key the light will keep turning on. Press it again, it’ll turn off. If the backlight setting is off, press any key will turn on the backlight except the PTT key. The backlight should be remaining for 5 seconds if no any keys pressed. The time out will be reset if any key pressed within the time frame.

CH/*/WX

(WX Channel: Only available for USA, Canada)

A short press of “CH/*/WX” key will trigger Private channel if there are private channels in memory. Pressing the “Up/Down” key will change private channel selection. A long press of “CH/*/WX” key will enter WX mode in USA or CAN Band. Pressing “Up/Down” key will change WX channel. The “WX” icon will be displayed on the screen.

Weather Alert Operation: (USA and CAN Band only)

When in the Weather mode, a long press the “CH/*/WX” key will switch on the Weather Alert function. Toggling the Weather Alert function ON/OFF. The icon “WAT” will be displayed accordingly, When Weather Alert function is enabled, every 4 seconds the last used weather channel will be checked for weather alert tone when the radio is tuned to working channel. With Weather Alert Function enabled, once the alert tone is detected, the “Weather Alarm” will be display and alarm sounds. After silencing the weather alarm, the radio will automatically tune to the current WX channel where the weather alert has been detected. The alert will be detected in the modes of Dual/Tri-watch, Scan operation etc.

6.Other Features and Solutions

Special function keys

1. After turning on the radio, press the PTT+CH*WX+CALL/MENU keys to enter the upgrade host mode. LCD display as below:

The software’s
Upgrading by PC
Please wait----

2. After turning on the radio, press PTT+SCAN+DW/FOG keys to enter the CLONE mode. LCD display as below:

The Private
Channels are
Cloning by PC
Please wait---

3. After turning on the radio, press the PTT+GPS/MOB+UIC keys to enter the reset code deletion mode. LCD display as below:

This will Delete
the MMSI and
The ATIS ID.
Are you sure?
no yes

4. After turning on the radio, press the PTT+Back Light On/Off+TRIW/HAIL keys to enter the upgrade handset software mode. LCD display as below:

Burn the handset
Software into
Main radio by PC
Please wait..

Connect the computer, upgrade the handset software to the host, cut off the power and restart the radio, then press the PTT+EXIT+ENTER keys on the handset until the screen displays

Upgrade
the Handset
software

Wait for the upgrade to complete, then power off and restart.

TX Time Out

The transmission will be automatically turned off after PTT key pressed over 5 consecutive minutes. The TX mode will be terminated and back to Rx mode. Once the PTT key is released, the TX time out timer will be reset. PTT key will back to work normally.

The Local Time & Date on Screen:



When HM390-BB cannot receive the GPS signal to display the current position, screen will automatic display the time and date. When radio received the GPS signal, screen will show the current GPS location, related UTC time and date will be shown below the GPS location mark.

Long press “Call/Menu” and enter “GPS Setup” to select the “Time offset” item for setting user’s local time based on UTC time. Then press “Enter” to confirm. User need to pass the entire item from hour-minute-second then able to see enter option to click and confirm.

In other words, the process is the same as your setup of local time on your computer.

MUTE Feature for Internal Speaker

When the crew is resting inside,you can operate only the external speaker by turning ON the MUTE feature.The internal speaker will have no sound when the MUTE feature works normally,so as not to disturb the crew to rest. This feature is enabled or disabled in the VHF menu.

NMEA 0183 and NMEA 2000

The HM390S-BB can be connected to both NMEA0183 and NMEA2000 networks. When you connect your radio to a NMEA 0183 network or a NMEA2000 network, the following data can be transferred; the radio can receive GPS position. GPS position can be displayed on the screen and is transmitted with DSC calls. When GPS data is not present, the radio will signal for you to enter your position manually every four hours.When the

GPS data does not exist, the radio will signal you to manually enter a position every four hours.

This setting indicates whether you are connected to a NMEA 0183 or NMEA 2000 network; the radio can communicate over two networks at the same time.

The interface used for NMEA0183 is RS232

Compass safe distance is 0.8m

Appendix A-List of Abbreviations

AE	Auxiliary Equipment
CE	Conducted Emissions
EMC	Electromagnetic Compatibility
EN	European Norm
EUT	Equipment Under Test
FTB	Fast Transient Burst
MED	Marine Equipment Directive
QP	Quasi Peak

HM390S-BB/HM390C-BB AND NMEA2000 COMMUNICATION PGN

HM390S-BB SEND NMEA2000 PGN:

59392	ISO acknowledgement
60928	ISO Address Claim
126208	Nmea request/command/acknowledge Group function
126464	PGN List
126720	fast data packet, multi_frame, proprietary PGN
126996	Product information
129799	Radio frequency/Mode/power
129025	Position,rapid update
129026	COG/SOG Rapid update
129033	time & date update
129038	Class A position report (Rx,Tx) note:ais msg 1/2/3
129039	Class B position report (Rx,Tx) note:ais msg 18
129040	Class B ext_position report (Rx,Tx) note:ais msg 19
129793	UTC and date report (Tx) note:ais msg 4/11
129794	Class A static and voyage related data (Rx,Tx) note:ais msg 5
129801	Addressed safety msg (Rx,Tx) note:ais msg 12
129802	Broadcast safety msg (Rx,Tx) note:ais msg 14
129808	Dsc call information
129809	AIS Class B 'CS'Static Data Report, Part A note:ais msg 24A
129810	AIS Class B 'CS'Static Data Report, Part B note:ais msg 24B

HM390C-BB SEND NMEA2000 PGN:

59392	ISO acknowledgement
60928	ISO Address Claim
126208	Nmea request/command/acknowledge Group function
126464	PGN List
126720	fast data packet,multi_frame, proprietary PGN
126996	Product information
129025	Position,rapid update
129026	COG/SOG Rapid update
129033	time & date update
129799	Radio frequency/Mode/power
129808	Dsc call information

HM390C-BB AND HM390S-BB RECEIVE NMEA2000 PGN:

59392	ISO acknowledgement
59904	ISO request
60928	ISO Address Claim
126208	Nmea request/command/acknowledge Group function
126464	PGN List
129026	COG/SOG Rapid update
129029	GNSS Position data

International Marine VHF Channels & Frequencies

CH	TX Freq	RX Freq	Simple	Freq Use
01	156.050	160.650		Public Correspondence, Port Operations and Ship Movement
02	156.100	160.700		Public Correspondence, Port Operations and Ship Movement
03	156.150	160.750		Public Correspondence, Port Operations and Ship Movement
04	156.200	160.800		Public Correspondence, Port Operations and Ship Movement
05	156.250	160.850		Public Correspondence, Port Operations and Ship Movement
06	156.300	156.300	x	Inter-ship [1]
07	156.350	160.950		Public Correspondence, Port Operations and Ship Movement
08	156.400	156.400	x	Inter-ship
09	156.450	156.450	x	Inter-ship, Port Operations and Ship Movement
10	156.500	156.500	x	Inter-ship, Port Operations and Ship Movement [2]
11	156.550	156.550	x	Port Operations and Ship Movement
12	156.600	156.600	x	Port Operations and Ship Movement
13	156.650	156.650	x	Inter-ship Safety, Port Operations and Ship Movement [3]
14	156.700	156.700	x	Port Operations and Ship Movement
15	156.750	156.750	x	Inter-ship and On-board Communications at 1W only [4]
16	156.800	156.800	x	Distress, Safety and Calling
17	156.850	156.850	x	Inter-ship and On-board Communications at 1W only [4]
18	156.900	161.500		Public Correspondence, Port Operations and Ship Movement
19	156.950	161.550		Public Correspondence, Port Operations and Ship Movement
1019	156.950	156.950	x	Public Correspondence, Port Operations and Ship Movement
2019	RX Only	161.550		Public Correspondence, Port Operations and Ship Movement
20	157.000	161.600		Public Correspondence, Port Operations and Ship Movement
1020	157.000	157.000	x	Public Correspondence, Port Operations and Ship Movement
2020	RX Only	161.600		Public Correspondence, Port Operations and Ship Movement
21	157.050	161.650		Public Correspondence, Port Operations and Ship Movement
22	157.100	161.700		Public Correspondence, Port Operations and Ship Movement
23	157.150	161.750		Public Correspondence, Port Operations and Ship Movement
1027	157.350	157.350	x	Public Correspondence
1028	157.400	157.400	x	Public Correspondence
60	156.025	160.625		Public Correspondence, Port Operations and Ship Movement
61	156.075	160.675		Public Correspondence, Port Operations and Ship Movement
62	156.125	160.725		Public Correspondence, Port Operations and Ship Movement
63	156.175	160.775		Public Correspondence, Port Operations and Ship Movement
64	156.225	160.825		Public Correspondence, Port Operations and Ship Movement
65	156.275	160.875		Public Correspondence, Port Operations and Ship Movement
66	156.325	160.925		Public Correspondence, Port Operations and Ship Movement
67	156.375	156.375	x	Inter-ship, Port Operations and Ship Movement [2]
68	156.425	156.425	x	Port Operations and Ship Movement
69	156.475	156.475	x	Inter-ship, Port Operations and Ship Movement
71	156.575	156.575	x	Port Operations and Ship Movement

72	156.625	156.625	x	Inter-ship
73	156.675	156.675	x	Inter-ship [2]
74	156.725	156.725	x	Port operations and Ship movement
75	156.775	156.775	x	See Note [5]
76	156.825	156.825	x	See Note [5]
77	156.875	156.875	x	Inter-ship
78	156.925	161.525		Public correspondence, Port Operations and Ship Movement
1078	156.925	156.925	x	Public correspondence, Port Operations and Ship Movement
2078	RX Only	161.525		Public correspondence, Port Operations and Ship Movement
79	156.975	161.575		Public correspondence, Port Operations and Ship Movement
1079	156.975	156.975	x	Public correspondence, Port Operations and Ship Movement
2079	RX Only	161.575		Public correspondence, Port Operations and Ship Movement
80	157.025	161.625		Public correspondence, Port Operations and Ship Movement
81	157.075	161.675		Public correspondence, Port Operations and Ship Movement
82	157.125	161.725		Public correspondence, Port Operations and Ship Movement
83	157.175	161.775		Public correspondence, Port Operations and Ship Movement
87	157.375	157.375	x	Port Operations and Ship Movement
88	157.425	157.425	x	Port Operations and Ship Movement

- ◆ Inter-ship channels are for communications between ship stations. Inter-ship communications should be restricted to Channels 6, 8, 72 and 77. If these are not available, the other channels marked for Inter-ship may be used.
- ◆ Channel 70 is used exclusively for Digital Selective Calling (DSC) and is not available for regular voice communications.

Notes:

1. Channel 06 may also be used for communications between ship stations and aircraft engaged in coordinated search and rescue operations. Ship stations should avoid harmful interference to such communications on channel 06 as well as to communications between aircraft stations, ice breakers and assisted ships during ice seasons.
2. Within the European Maritime Area and in Canada, channels 10, 67 and 73 may also be used by the individual administrations concerned for communication between ship stations, aircraft stations and participating land stations engaged in coordinated search and rescue and anti-pollution operations in local areas. Channels 10 or 73 (depending on location)

are also used for the broadcast of Marine Safety Information by the Maritime and Coast Guard Agency

in the UK only.

3. Channel 13 is designated for use on a worldwide basis as a navigation safety communication channel, primarily for inter-ship navigation safety communications.
4. Channels 15 and 17 may also be used for on-board communications provided the effective radiated power does not exceed 1 Watt.
5. The use of Channels 75 and 76 should be restricted to navigation related communication only and all precautions should be taken to avoid harmful interference to channel 16. Transmit power is limited to 1 Watt.

U.S. Marine VHF Channels and Frequencies

CH	TX Freq	RX Freq	Simplex	Freq Use
1001	156.050	156.050	x	Port Operations and Commercial, VTS. Available only in New Orleans / Lower Mississippi area.
1003	156.150	156.150	x	U.S. Government only
1005	156.250	156.250	x	Port Operations or VTS in the Houston, New Orleans and Seattle areas.
06	156.300	156.300	x	Inter-ship Safety
1007	156.350	156.350	x	Commercial
08	156.400	156.400	x	Commercial (Inter-ship only)
09	156.450	156.450	x	Boater Calling. Commercial and Non-Commercial.
10	156.500	156.500	x	Commercial
11	156.550	156.550	x	Commercial. VTS in selected areas.
12	156.600	156.600	x	Port Operations. VTS in selected areas.
13	156.650	156.650	x	Inter-ship Navigation Safety (Bridge-to-bridge). Ships >20meters in length maintain a listening watch on this channel in US waters.
14	156.700	156.700	x	Port Operations. VTS in selected areas.
15	RX Only	156.750		Environmental (Receive only). Used by Class 'C' EPIRBS.
16	156.800	156.800	x	International Distress, Safety and Calling. Ships required to carry radio, USCG, and most coast stations maintain a listening watch on this channel.
17	156.850	156.850	x	State Control
1018	156.900	156.900	x	Commercial
1019	156.950	156.950	x	Commercial
20	157.000	161.600		Port Operations (duplex)
1020	157.000	157.000	x	Port Operations
1021	157.050	157.050	x	U.S. Coast Guard only
1022	157.100	157.100	x	Coast Guard Liaison and Maritime Safety Information Broadcasts. Broadcasts announced on channel 16.
1023	157.150	157.150	x	U.S. Coast Guard only
1027	157.350	157.350	x	PC Public Correspondence
1028	157.400	157.400	x	PC Public Correspondence
1061	156.075	156.075	x	U.S. Government only
1063	156.175	156.175	x	Port Operations and Commercial, VTS. Available only in New Orleans / Lower Mississippi area.
1064	156.225	156.225	x	U.S. Coast Guard only
1065	156.275	156.275	x	Port Operations
1066	156.325	156.325	x	Port Operations
67	156.375	156.375	x	Commercial. Used for Bridge-to-bridge communications in lower Mississippi River. Inter-ship only.
68	156.425	156.425	x	Non-Commercial
69	156.475	156.475	x	Non-Commercial
70	156.525	156.525	x	Non-Commercial

71	156.575	156.575	x	Non-Commercial
72	156.625	156.625	x	Non-Commercial (Inter-ship only)
73	156.675	156.675	x	Port Operations
74	156.725	156.725	x	Port Operations
77	156.875	156.875	x	Port Operations (Inter-ship only)
1078	156.925	156.925	x	Non-Commercial
1079	156.975	156.975	x	Commercial. Non-Commercial in Great Lakes only.
1080	157.025	157.025	x	Commercial. Non-Commercial in Great Lakes only
1081	157.075	157.075	x	U.S. Government only – Environmental protection operations.
1082	157.125	157.125	x	U.S. Government only
1083	157.175	157.175	x	U.S. Coast Guard only
87	157.375	157.375	x	Public Correspondence Marine Operator)
88	157.425	157.425	x	Public Correspondence only near Canadian border

- ◆ Recreational boaters normally use channels listed as Non-Commercial: 68, 69, 71, 72, 1078.
- ◆ Channel 70 is used exclusively for Digital Selective Calling (DSC) and is not available for regular voice communications.
- ◆ Channel 16 and are not available for regular voice communications.

Notes:

1. The digits “10” following a channel number indicates simplex use of the ship station transmit side of an international semi-duplex channel. Operations are different from that of international operations on that channel.
2. Channel 13 should be used to contact a ship when there is danger of collision. All ships of length 20 meters or greater are required to guard VHF channel 13, in addition to VHF channel 16, when operating within U.S. territorial waters.
3. Channel is Receive Only.
4. Channel 16 is used for calling other stations or for distress alerting.
5. Output power is fixed at 1 watt only.
6. Output power is initially set to 1 watt. User can temporarily override this restriction to transmit at high power.

Canadian Marine VHF Channels and Frequencies

CH	TX Freq	RX Freq	Simple	Area of Operation Use
01	156.050	160.650		PC Public Correspondence
02	156.100	160.700		PC Public Correspondence
03	156.150	160.750		PC Public Correspondence
1004	156.200	156.200	x	PC Inter-ship, Ship/Shore and Safety: Canadian Coast Guard S&R
1005	156.250	156.250	x	Ship Movement
06	156.300	156.300	x	All areas Inter-ship, Commercial, Non commercial and Safety: May Be used for search and rescue communications between ships and aircraft.
1007	156.350	156.350	x	All areas Inter-ship, Ship/Shore, Commercial
08	156.400	156.400	x	WC, EC Inter ship, Commercial and Safety: Also assigned for operations in the Lake Winnipeg area.
09	156.450	156.450	x	AC Inter-ship, Ship/Shore, Commercial, Non-commercial and Ship Movement: May be used to communicate with aircraft and Helicopters in predominantly maritime support operations.
10	156.500	156.500	x	AC, GL Inter-ship, Ship/Shore, Commercial, Non-commercial, Safety and Ship Movement: May also be used for communications with aircraft engaged in coordinated search and rescue and antipollution operations.
11	156.550	156.550	x	PC, AC, GL Inter-ship, Ship/Shore, Commercial, Non-commercial and Ship Movement: Also used for pilotage purposes.
12	156.600	156.600	x	WC, AC, GL Inter-ship, Ship/Shore, Commercial, Non-commercial and Ship Movement: Port operations and pilot information and messages.
13	156.650	156.650	x	All areas Inter-ship, Commercial, Non-commercial and Ship Movement: Exclusively for bridge-to-bridge navigational traffic. Limited to 1-watt maximum power.
14	156.700	156.700	x	AC, GL Inter-ship, Ship/Shore, Commercial, Non-commercial and Ship Movement: Port operations and pilot information and Messages.
15	156.750	156.750	x	All areas Inter-ship, Ship/Shore, Commercial, Non-commercial and Ship Movement: All May also be used for on-board Communications.
16	156.800	156.800	x	All areas International Distress, Safety and Calling.
17	156.850	156.850	x	All areas Inter-ship, Ship/Shore, Commercial, Non-commercial and Ship Movement: All operations limited to 1-watt maximum power. May also be used for on-board Communications.
1018	156.900	156.900	x	All areas Inter-ship, Ship/Shore and Commercial: Towing on the Pacific Coast.
1019	156.950	156.950	x	All areas except PC Inter-ship and Ship/Shore: Canadian Coast Guard only.
20	157.000	161.600		All areas Ship/Shore, Safety and Ship Movement: Port operation
1021	157.050	157.050	x	All areas Inter-ship and Ship/Shore: Canadian Coast Guard only.
2021	RX Only	161.650		All areas Safety: Continuous Marine Broadcast (CMB) service.

1022	157.100	157.100	x	All areas Inter-ship, Ship/Shore, Commercial and Non-commercial: For communications between Canadian Coast Guard and non-Canadian Coast Guard stations only.
23	157.150	161.750		PC Ship/Shore and Public Correspondence: Also in the inland waters of British Columbia and the Yukon.
2023	RX Only	161.750		Continuous Marine Broadcast Service
1027	157.350	157.350	x	PC Ship/Shore and Public Correspondence
1028	157.400	157.400	x	PC Ship/Shore and Public Correspondence
60	156.025	160.625		PC Ship/Shore and Public Correspondence.
61	156.075	160.675		PC Ship/Shore and Public Correspondence
1061	156.075	156.075	x	EC Inter-ship, Ship/Shore and Commercial: Commercial fishing only.
1062	156.125	156.125	x	EC Inter-ship, Ship/Shore and Commercial: Commercial fishing only.
1063	156.175	156.175	x	Tow Boats - BCC area
64	156.225	160.825		PC Ship/Shore and Public Correspondence
1064	156.225	156.225	x	EC Inter-ship, Ship/Shore and Commercial: Commercial fishing only.
1065	156.275	156.275	x	Inter-ship, Ship/Shore, Commercial, Non-commercial, Safety: Search & rescue and antipollution operations on the Great Lakes. Towing on the Pacific Coast. Port operations only in the St. Lawrence River areas with 1W maximum power. Pleasure craft in the inland waters of Alberta, Saskatchewan and Manitoba (excluding Lake Winnipeg and the Red River).
1066	156.325	156.325	x	Inter-ship, Ship/Shore, Commercial, Non-commercial, Safety and Ship Movement:Port operations only in the St.Lawrence River/Great Lakes Areas with 1-watt maximum power.
67	156.375	156.375	x	All areas except EC Inter-ship, Ship/Shore, Commercial, Non-commercial, Safety:May also be used for communications with aircraft engaged in coordinated search and rescue and antipollution operations.
68	156.425	156.425	x	All areas Inter-ship, Ship/Shore and Non-commercial: For marinas and yacht clubs.
69	156.475	156.475	x	All areas except EC Inter-ship, Ship/Shore, Commercial and Non-commercial
71	156.575	156.575	x	PC Inter-ship, Ship/Shore, Commercial, Non-commercial, Safety and Ship Movement the East Coast and on Lake Winnipeg.
72	156.625	156.625	x	EC, PC Inter-ship, Commercial and Non-commercial: May be used to communicate with aircraft and helicopters in predominantly maritime support
73	156.675	156.675	x	All areas except EC Inter-ship, Ship/Shore, Commercial, Non-commercial, Safety:May also be used for communications with aircraft engaged in coordinated search and rescue and antipollution operations.
74	156.725	156.725	x	EC, PC Inter-ship, Ship/Shore, Commercial, Non-commercial and Ship Movement.
75	156.775	156.775	x	Simplex port operation, Ship movement and navigation related communication only. 1 watt maximum

76	156.825	156.825	x	Simplex port operation, Ship movement and navigation related communication only.1 watt maximum
77	156.875	156.875	x	Inter-ship, Ship/Shore, Safety and Ship Movement: Pilotage on Pacific Coast. Port operations only in the St. Lawrence River/Great Lakes areas with 1W maximum power.
1078	156.925	156.925	x	EC, PC Inter-ship, Ship/Shore and Commercial
1079	156.975	156.975	x	EC, PC Inter-ship, Ship/Shore and Commercial
1080	157.025	157.025	x	EC, PC Inter-ship, Ship/Shore and Commercial
1081	157.075	157.075	x	Inter-ship and Ship/Shore: Canadian Coast Guard use only in the St. Lawrence River/ Great Lakes areas.
1082	157.125	157.125	x	Inter-ship and Ship/Shore: Canadian Coast Guard use only in the St. Lawrence River/ Great Lakes areas.
83	157.175	161.775		PC Ship/Shore and Public Correspondence
1083	157.175	157.175	x	EC Inter-ship and Ship/Shore: Canadian Coast Guard and other Government agencies.
2083	RX Only	161.775		AC, GL Safety: Continuous Marine Broadcast (CMB) Service.
87	157.375	157.375	x	AC, GL, NL Ship/Shore and Public Correspondence
88	157.425	157.425	x	AC, GL, NL Ship/Shore and Public Correspondence

AC: Atlantic Coast, Gulf and St. Lawrence River up to and including Montreal

EC: (East Coast): includes NL, AC, GL and Eastern Arctic areas

GL: Great Lakes (including St. Lawrence above Montreal)

NL: Newfoundland and Labrador

PC: Pacific Coast

WC:(West Coast): Pacific Coast, Western Arctic and Athabasca-Mackenzie Watershed areas All areas: includes East and West Coast areas

Notes:

1. The digits “10” following a channel number indicates simplex use of the ship station transmit side of an international

2. duplex channel. Operations are different from that of international operations on that channel.
3. Channel 16 is used for calling other stations or for distress alerting.
4. The digits “20” following a channel number indicates simplex use of the coast station transmit side of an international duplex channel. That is, the channel is Receive Only.
5. Channel 70 is used exclusively for Digital Selective Calling (DSC) and is not available for regular voice communications.
6. Channels 75 and 76 are reserved as guard bands for Channel 16 and are not available for regular voice communications.

European Private Channels and Frequencies

In addition to the channels listed above in the International Marine VHF Channels & Frequencies table, your radio may also include some of the following private channels. Which channels are included depend upon the country in which the radio is to be operated and whether you possess the appropriate licensing

Country	CH	TX Freq	RX Freq	Freq Use
Belgium	96	162.425	162.425	Marina
Denmark	L1	155.500	155.500	Leisure
	L2	155.525	155.525	Leisure
Denmark, Finland, Norway & Sweden	F1	155.625	155.625	Fishing
	F2	155.775	155.775	Fishing
	F3	155.825	155.825	Fishing
Finland, Norway&Sweden	L1	155.500	155.500	Leisure
	L2	155.525	155.525	Leisure
	L3	155.650	155.650	Leisure
Netherlands	31	157.550	162.150	Marina
	37	157.850	157.850	Leisure
UK	M1	157.850	157.850	Marina
	M2	161.425	161.425	Marina

Note: A license may be required to operate the radio on the private channels. It is your responsibility to obtain the proper license to operate the radio on these frequencies.

Weather Channels and Frequencies

WX channel	Frequency(MHz)		Remarks
	Transmit	Receive	
1	RX only	162.550	Weather(receive only)
2	RX only	162.400	Weather(receive only)
3	RX only	162.475	Weather(receive only)
4	RX only	162.425	Weather(receive only)
5	RX only	162.450	Weather(receive only)
6	RX only	162.500	Weather(receive only)
7	RX only	162.525	Weather(receive only)
8	RX only	161.650	Weather(receive only)
9	RX only	161.775	Weather(receive only)
10	RX only	163.275	Weather(receive only)

Specifications

---VHF radio

TX Frequency.....	156.025--157.425MHz
RX Frequency.....	156.300--162.000MHz
Digital Selectivity Calling (DSC).....	Class-D with dual receiver (individual CH70)
CH70.....	156.525MHz
Channel spacing.....	25kHz
Channel banks.....	All INT/USA/Canadian 10 WX (only available for USA and Canada)
Modulation mode.....	FM (16K0G3E), DSC/ATIS (16K0G2B)
Antenna impedance.....	50Ω (nominal)
Power supply.....	13.8V DC
Sensitivity at 12dB SINAD.....	≤-5 dBμV (EMF)
Squelch sensitivity.....	≤-5 dBμ (EMF)
Spurious Resp.Rej.....	70 dB
Adjacent Channel Rejection.....	70 dB
Audio output power.....	5W @ 4Ω
Audio Power Output (hailer).....	30W @ 4Ω
Audio Distortion.....	5%
RF Output power.....	High:25W / Low:1W
Harmonic Emissions.....	0.25μW
Current drain, Stdby / TX (high) / RX.....	0.5A/ 6A / 1A (@ 13.8V
Maximum frequency deviation.....	±5.0kHz
Local Oscillator mode.....	PLL
Ambient operating temperatures.....	-15°C to +55°C
Waterproof.....	IP67
Compass safe distance.....	0.8m
Buddy list.....	20/50/100
Private channels.....	99

---Communications

Comm. port NMEA 0183.....	9600 baud
Comm. port NMEA 2000 (HM390C-BB\HM390S-BB only).....	NMEA 2000
NMEA 0183 input (receive).....	RMC, GGA, GLL, ZDA, VTG, GSV
NMEA 0183 output (transmit).....	DSC (for DSC call), DSE (for enhanced position) AIVDM (AIS)

---AIS Receiver

Frequency.....	161.9750MHz/162.025MHz
Number of Channels.....	(2) Dual Channels

---Dimension & Weight

Fixed unit dimensions (L/W/H).....	210 mm x 111 mm x 57 mm
Fixed unit dimensions on mounting bracket.....	216 mm x 134 mm x 57 mm
Fixed unit Weight.....	1.2 kg

---GPS

Channels.....	56
Sensitivity.....	Tracking:-161dBm Reacquisition:-160dBm ColdStart:-147dBm
Cold Start/ Hot Start.....	60 s econds, average/40 second, average

Declaration of Conformity

We, the undersigned (Manufacturer / The manufacturers authorized representative established within EEA):

Company	Shenzhen Jiuzhou Himunication Technology Co., Ltd
Address	7th Floor, building 13, Run Dong Sheng Industrial Park, National Road 107,Xixiang, Baoan district, Shenzhen, China
Country	China
Telephone number	13713517852
Telefax number	-
E-mail	rd@himunication.com

Certify and declare under our responsibility that the following product:

Product Description	Fixed Marine Radio
Manufacturer	Shenzhen Jiuzhou Himunication Technology Co., Ltd
Brand Name	HIMUNICATION
Model/Type	HM390S, HM390C-BB, HM390-BB, HM390-BBN, HM390C, HM390, HM390 Non DSC, HM390S-BB
Hardware version	-
Software version	-

Is tested to and conforms with the essential test suites included in the following standards, which are in force within the EEA:

Standard	Issue date	Reference to report/file
EN 50385:2017	2022-04-21	CHTEW22040154
ETSI EN 301 025 V2.2.1 (2017-03) ETSI EN 300 338-3 V1.2.1 (2017-02)	2022-04-21	CHTEW2204015401
ETSI EN 303 413 V1.1.1: 2017-06	2022-04-21	CHTEW2204015402
ETSI EN 301 843-1 V2.2.1 (2017-11) ETSI EN 301 843-2 V2.2.1 (2017-11)	2022-04-21	CHTEW2204015403
ETSI EN 301 489-1 V2.2.3 (2019-11) ETSI EN 301 489-19 V2.1.1 (2019-04)	2022-04-21	CHTEW2204015404
IEC 62368-1:2018 EN IEC 62368-1:2020+A11:2020	2022-04-24	CHTSE22040132

And therefore complies with the essential requirements of the following directives:

Directive Name	Directive number	Further identification
Radio Equipment Directive	2014/53/EU	

The following Notified Bodies have been consulted in the Conformity Assessment procedure (whenever applicable):

Notified Body number	Name and address
1622	Nemko Canada Inc 303 River Road Ottawa, Ontario, Canada K1V 1H2

The technical documentation as required by the conformity assessment procedure is kept at the following address for a period ending at least 10 years after the last product has been manufactured at the disposal of the relevant national authorities of any Member State for inspection:

Company	Shenzhen Jiuzhou Himunication Technology Co., Ltd
Address	7th Floor, building 13, Run Dong Sheng Industrial Park, National Road 107,Xixiang, Baoan district, Shenzhen, China
Country	China
Telephone number	13713517852
Telefax number	-
E-mail	rd@himunication.com

Product is CE-marked in	
--------------------------------	--



Drawn up in	
Date	2022-05-19
<i>Oliver Zou</i>	
Signature and Company Stamp	Oliver Zou